

Datasheet

Luna bench of cm. 180

Product code 435

Rev. 1 of 12/07/2019



1/5

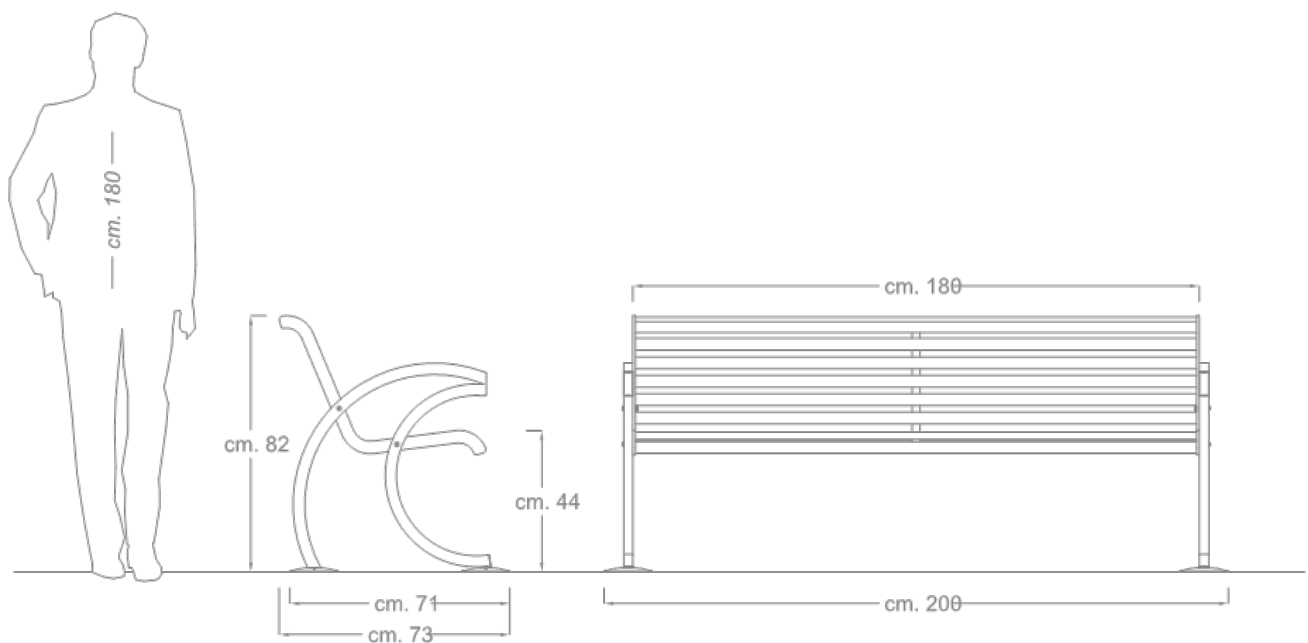

Dimcar reserves the right to make, at any time, changes on the products deemed useful to improve the quality of the same; the images contained in the sheets may not faithfully reproduce the real colors of the items.

Datasheet

Luna bench of cm. 180

Product code 435

Rev. 1 of 12/07/2019



DESCRIPTION

Structure

Luna bench composed of N. 2 arched supports in rectangular galvanized tube mm. 40x30x2. Each support is equipped with circular plates at the base for fixing to the ground.

- Seat-backrest shell made with N. 14 profiles in oval section galvanized steel tube mm. 40x20x1.5.
- The profiles are welded on special galvanized steel templates that give it the anatomical shape.

Overall weight: 50Kg

Datasheet

Luna bench of cm. 180

Product code 435

Rev. 1 of 12/07/2019



COLOR FINISH AS PROVIDED IN THE CATALOG



RAL 3015
(Steel parts)

Customers can request a different finish from the RAL color options available on our website.

PRODUCT VARIANTS



[Product code 435-I - Luna bench inclusion cm. 200](#)

Datasheet

Luna bench of cm. 180

Product code 435

Rev. 1 of 12/07/2019



ANTICORROSIVE TREATMENTS AND FINISHES

Washing

Spray treatment for removing oil and grease from metal surfaces using special degreasing liquids. Subsequent drying in dryer for 15 minutes.

Sandblasting

Manual sandblasting process with river sand, which increases the porosity of metal surfaces and thus the adhesion of thermosetting powders.

Anti-corrosive application

First painting cycle with an anticorrosive thermosetting powder primer based on epoxy resins and special pigments. It provides adequate protection against weathering.

Anticorrosive polymerization

Baking in an industrial curing oven at a temperature of 180°C. During this stage, the powder turns into a uniform, smooth and durable coating.

Colored finish application

Final coating cycle with thermosetting powders. Application follows the same principles as the anticorrosive.

Polymerization colored finish

Final baking in an industrial curing oven at a temperature of 180°C. The procedure follows the same principles as the curing of the anticorrosive. The powder is transformed into a uniform coating, and the surface appearance takes on the characteristics of the chosen color type, e.g. smooth, textured, wrinkled, etc.

Datasheet

Luna bench of cm. 180

Product code 435

Rev. 1 of 12/07/2019



DELIVERY

Product supplied in assembly kit with steel hardware and instructions for mounting and grounding.

FIXING

The product is prepared for fixing to the ground using anchor bolts and expansion plugs.

CORPORATE CERTIFICATIONS

ISO 9001:2015

Quality management system.

UNI EN ISO 3834-3:2021

Welding quality management system.

Processing center

Certificate of Processing Center